

## **Timing Belt Change for Isuzu MU 2.8TD (4JB1T Motor)**

### **Timing Belt Part No. Gates T966**

*Note: Timing Belt must be removed and refitted when the engine is cold  
Spring balance or 9 KG weight is required.*

#### **Stage 1**

##### **Cooling Fan and Crankshaft pulley**

- 1 Remove cooling fan and coupling.
- 2 Remove the auxiliary drive belts
- 3 Slacken and remove the four bolts securing the Crankshaft pulley to its hub and remove the pulley from the vehicle. If the locating pin is a loose fit, remove it and store it with the pulley for safe keeping.

#### **Stage 2**

##### **Removing timing belt**

- 1 Position No 1 cylinder at TDC on its compression stroke as described at the end of this section.
- 2 Remove the timing belt lower cover.
- 3 Lock the camshaft and injection pump sprockets in position by inserting M8 bolts through the sprocket timing holes and screwing them into the threaded holes in the backplate. Check that the crankshaft pulley hub hole/pin is correctly aligned with the TDC pointer on the backplate (see illustration 8.4 Page 2)
- 4 Undo the retaining screws and remove the timing belt guide plates from the camshaft and injection pump sprockets (see illustration 8.5 page 2).
- 5 Loosen the timing belt tensioner pulley retaining bolt and pivot the pulley away from the belt.
- 6 Slide the timing belt from its sprockets and remove it from the engine. If the belt is to be re-used, use white paint or similar to mark the direction of rotation on the belt. Do not rotate the crankshaft until the timing belt has been refitted.

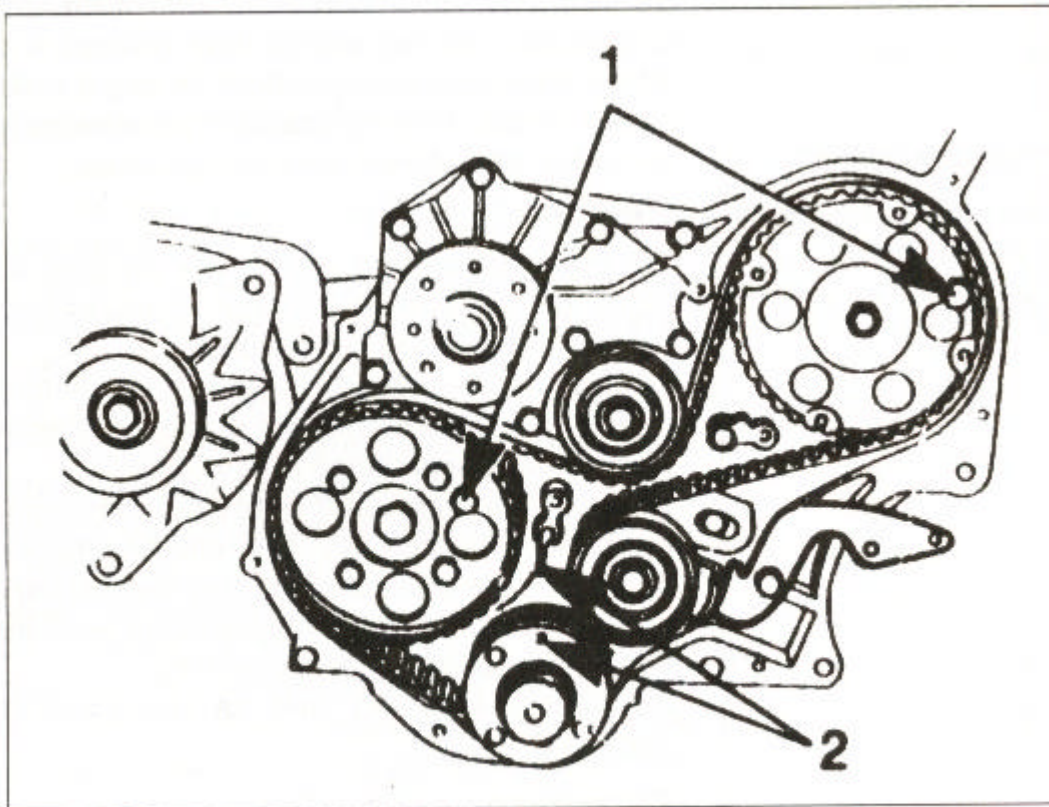

8.4 With No 1 cylinder at TDC on its compression stroke, lock the camshaft and injection pump sprockets in position with M8 bolts (1) and check the crankshaft pulley hub mark is aligned with the pointer (2)

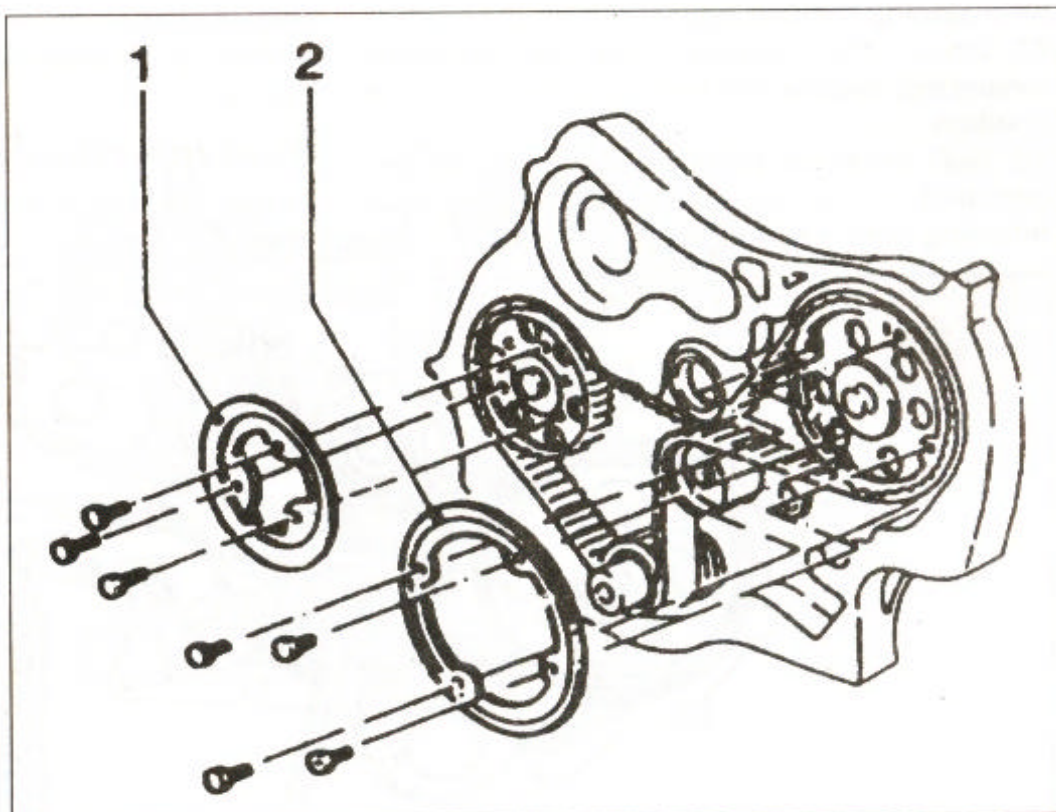

8.5 Undo the retaining screws and remove the camshaft and injection pump sprocket timing belt guides (1 and 2)

- 7 Check the timing belt carefully for any signs of uneven wear, splitting or oil contamination, and renew it if there is the slightest doubt about its condition. If the engine is undergoing an overhaul and has covered 100,000 Km or it was more than 4 years since the belt was fitted, renew the belt as a matter of course, regardless of its apparent condition. If signs of oil contamination are found, trace the source of the oil leak and rectify it, then wash down the engine timing belt area and all related components to remove all traces of oil.

### **Stage 3**

#### **Refitting**

- 1 On reassembly, thoroughly clean the timing belt sprockets and tensioner/idler pulleys.
- 2 Ensure that the camshaft and injection pump sprockets are still locked in position and make sure the crankshaft pulley hub hole/pin is still correctly aligned with the TDC pointer.
- 3 Fit the timing belt over the crankshaft and camshaft sprockets then around the idler pulley and over the injection pump sprocket. Ensure the belt is kept taut between the crankshaft, camshaft and injection pump sprockets (ie, so that all slack on the tensioner side of the belt) then fit the belt over the tensioner pulley. Do not twist the belt sharply while refitting it. Ensure that the belt teeth are correctly seated centrally in the sprockets, and that the timing marks remain in alignment. If a used belt is being refitted, ensure that the arrow mark made on removal points in the normal direction of rotation.
- 4 Free the tensioner lever and move the tensioner pulley towards the timing belt to remove all slack. Lightly tighten the pulley retaining bolt.
- 5 Ensure the crankshaft pulley hub mark is still correctly aligned with the TDC pointer then unscrew the locking bolts from the camshaft and injection pump sprockets.

- 6 Attach the spring balance/weight (as applicable) to the hole in the end of the tensioner pulley lever. With a load of 9 kg applied to the lever hole, slacken the tensioner pulley retaining bolt then securely retighten it (see illustration 8.14 below).

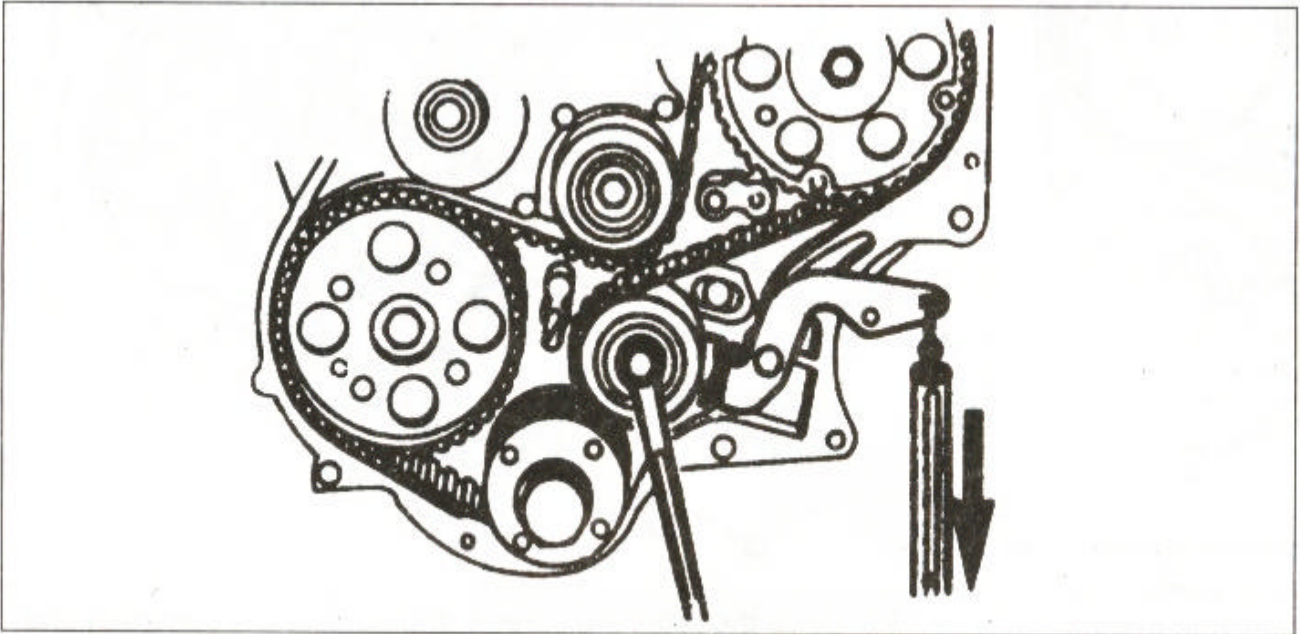

**8.14 Apply a load of 9 kg to the tensioner pulley lever and securely tighten the pulley bolt**

- 7 Using a socket on the crankshaft pulley hub bolt, rotate the crankshaft 45° in anti-clockwise direction to ensure that all slack is on the tensioner side of the timing belt. With a load of 9 kg applied to the hole on the end of the tensioner lever, slacken the tensioner pulley retaining bolt again then retighten it to the specified torque setting.
- 8 Remove the spring balance/weight from the tensioner lever then rotate the crankshaft back to TDC. Check the pulley hub pin/hole is correctly aligned with the TDC pointer and that both the camshaft and injection pump sprocket bolts can be screwed into position. If adjustment is necessary, release the tensioner then disengage the belt from the sprockets and make any necessary adjustments before retensioning the belt again.

- 9 Once the timing belt is correctly tensioned, secure the tensioner lever back in position.
- 10 Refit the guide plates to the camshaft and injection pump sprockets, tightening their retaining bolts securely.
- 11 Ensure the sprocket locking bolts have been removed then refit the timing belt covers and crankshaft pulley as described in page 1 stage 2.

### **Top Dead Centre (TDC) for Piston No 1 - Locating**

- 1 In its travel up and down its cylinder bore, Top Dead Centre (TDC) is the highest point that each piston reaches as the crankshaft rotates. While each piston reaches TDC both at the top of the compression stroke and again at the top of the exhaust stroke, for the purpose of timing the engine, TDC refers to the piston position (usually number 1) at the top of its compression stroke.
- 2 Number 1 piston (and cylinder) is at the front (timing belt) end of the engine, and its TDC position is located as follows. Note that the crankshaft rotates clockwise when viewed from the front of the vehicle.
- 3 Disconnect the battery negative terminal. To improve access to the crankshaft pulley, unbolt the undercover and remove it from underneath the engine.
- 4 Undo the retaining bolts and remove the timing belt upper cover to expose the injection pump timing belt sprocket. Take care not to lose the sealing strip from the rear of the cover.
- 5 Using a socket and extension bar on the crankshaft pulley bolt, rotate the crankshaft until the TDC notch on the pulley rim is correctly aligned with the pointer on the cover retaining bolt. Note that there are several notches on the pulley rim with the TDC notch being the largest; the other notches are used when setting the injection pump timing. With the

TDC notch correctly aligned with the pointer,  
No 1 and 4 pistons are at TDC (see illustration 3.5 on page 6).

- 6 To determine which piston is at TDC on its compression stroke, check the position of injection pump sprocket timing hole. If the hole is visible on the left-hand side of the sprocket then No 1 piston is at TDC on its compression stroke. If the timing hole is not visible then No 4 cylinder is at TDC on its compression stroke; rotate the crankshaft through a further complete turn (360°) to bring No 1 cylinder to TDC on its compression stroke.
- 7 With No 1 cylinder at TDC on its compression, the engine can be locked in position by inserting a M8 bolt through the injection pump sprocket timing hole and screwing it into the threaded hole in the backplate.

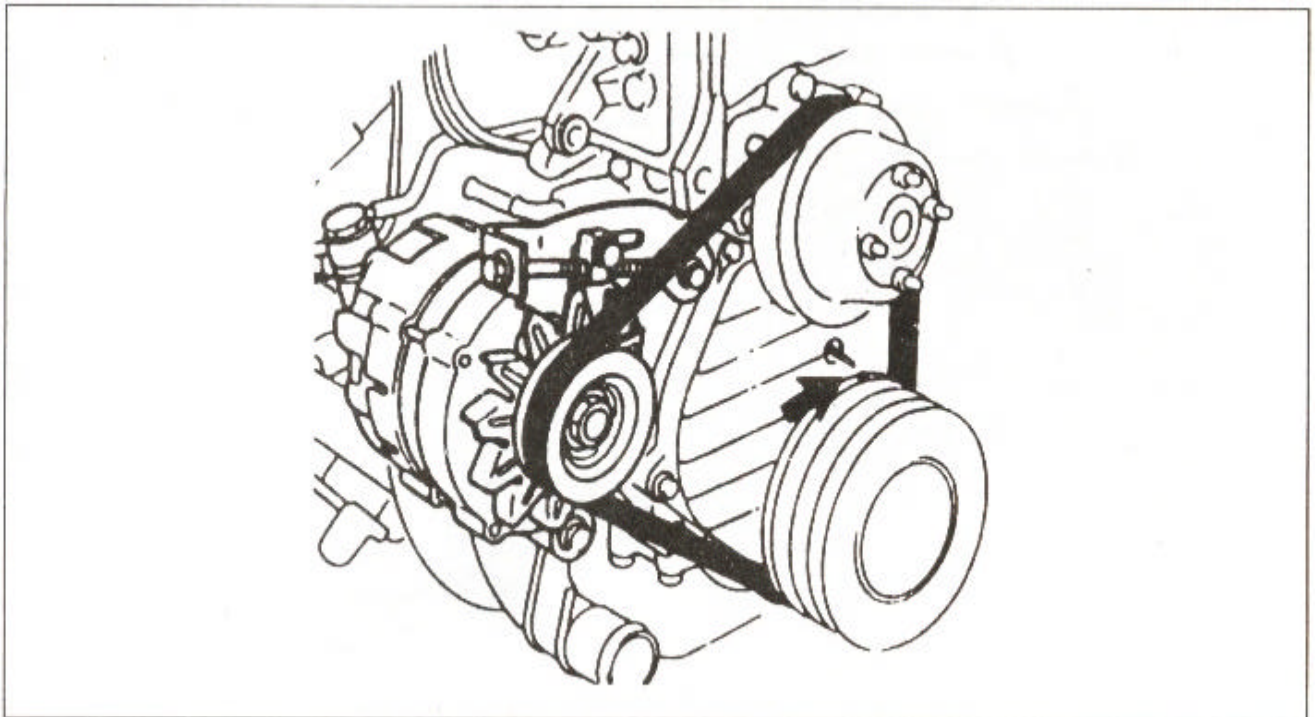

3.5 Align the crankshaft pulley TDC notch with the pointer (arrowed) to position No 1 and 4 pistons at TDC