

# Manual handling in the textiles industry



Health & Safety Commission  
Textiles Industry Advisory Committee

# Manual handling in the textiles industry

## What are the problems?

In textiles, manual handling causes more than a quarter of the work-related injuries reported each year. Around 60% of these involve an injury to the back, and some result in permanent disablement. Many injuries arise from stresses and strains over a period of time rather than from a single event.

## What are the causes?

Manual handling problems often stem from poor workplace or job design. Among the most common examples of risky activities are jobs involving: heavy or awkward loads; difficulty in gripping; excessive use of force; repetition; twisting and other awkward postures.

## What is the cost?

Costs to the company can come from: loss of production; poor product quality; sickness payments; accident injury claims and higher insurance premiums; high staff turnover; and retraining. Possible costs to the individual are: pain; possible permanent disability; time off work; and loss of earnings.

## What needs to be done: Assessing the risk

In the Health and Safety Executive (HSE) guidance on the Manual Handling Operations Regulations 1992,<sup>1</sup> a clear hierarchy of measures is established:

- Avoid hazardous manual handling so far as is reasonably practicable.
- Assess any hazardous handling operations that cannot be avoided.
- Reduce the risk of injury so far as is reasonably practicable.

The Regulations cover 'the transporting or supporting of loads by hand or by bodily force'. For example, they cover bale handling as well as moving drums of chemicals in a dyehouse. See the guidance booklet on the Regulations<sup>1</sup> for an example of an assessment checklist.

## Avoiding manual handling

Ask the following questions:

- Is manual handling necessary?
- Could the desired result be achieved in another way?
- Can the operations be mechanised or automated?

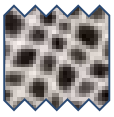

The main risks associated with manual handling activities are:

- the task - twisting, stooping, strenuous pushing and pulling etc;
- the load - weight, size, shape, stability, ease of grasp;
- the work environment - constraints on posture, poor floor surfaces, hot, cold or humid conditions;
- individual capabilities - health problems, the effects of protective equipment and clothing.

The Manual Handling Regulations do not cover the physical effort required in work which does not involve transporting or supporting a load. For instance, the action of lashing down the ropes on a wagon after loading is not covered, nor are the operation of controls of weaving or spinning machinery. Nevertheless, if the weaver or spinner cannot reach the controls easily, or operating the controls needs excessive force, injury can result. These risks would be considered in the risk assessment required by the Management of Health and Safety at Work Regulations 1992.<sup>2</sup>

## Assess the risks

In deciding whether an activity presents a risk, consider the following:

- Is excessive force required?
- Are there any complaints of aches and pains from workers? Also check with safety committees.
- Is there any evidence of improvised changes to controls or equipment?
- Are tools or equipment the wrong size for the user, or for the job to be done?
- Does the work require awkward postures such as stooping or stretching?
- Is there sufficient space to move around?
- Are there any reports of accidents or injuries associated with manual handling?
- Ask the employees which tasks are the most arduous.

## Practical ways to reduce the risks

A recent study of handling operations in the textile industry identified several common tasks where handling injury risk factors were evident. The following examples illustrate some of these factors and show possible ways of reducing or eliminating them.



## Handling bales

**Location:** Usually in delivery and storage areas.

**Problems:** Bales are generally too heavy to be handled without mechanical help. The manual movement of bales can present a serious risk of injury and even the use of hand trucks should be kept to a minimum.

**Solutions:** Figure 1 shows how the risks to an individual can be reduced by having more than one worker doing the



*Figure 1* Two workers help another with the difficult task of getting a bale onto a hand truck

job, particularly when getting the bale onto a truck. All the workers are using hand hooks to grip the bale. Also consider using lift and clamp trucks more widely, providing roller conveyors, using appropriate hand trucks for the

bales being moved, and maintaining floor surfaces to reduce risks.

## Handling bundles of processed fibre

**Location:** Packaging areas and close to carding and gilling machines.

**Problems:** The size, shape, and weight of the bundle (typically 9 to 22 kg); the repetitive nature of the task; the reaching and stooped postures adopted when lifting from bins; and the forces needed to pull and manoeuvre the bundles before lifting. Figure 2 shows a typical container bin used to collect bundles before they are transferred to packing containers. The worker has to lean and reach into the



*Figure 2* A typical reaching posture when working at a bin

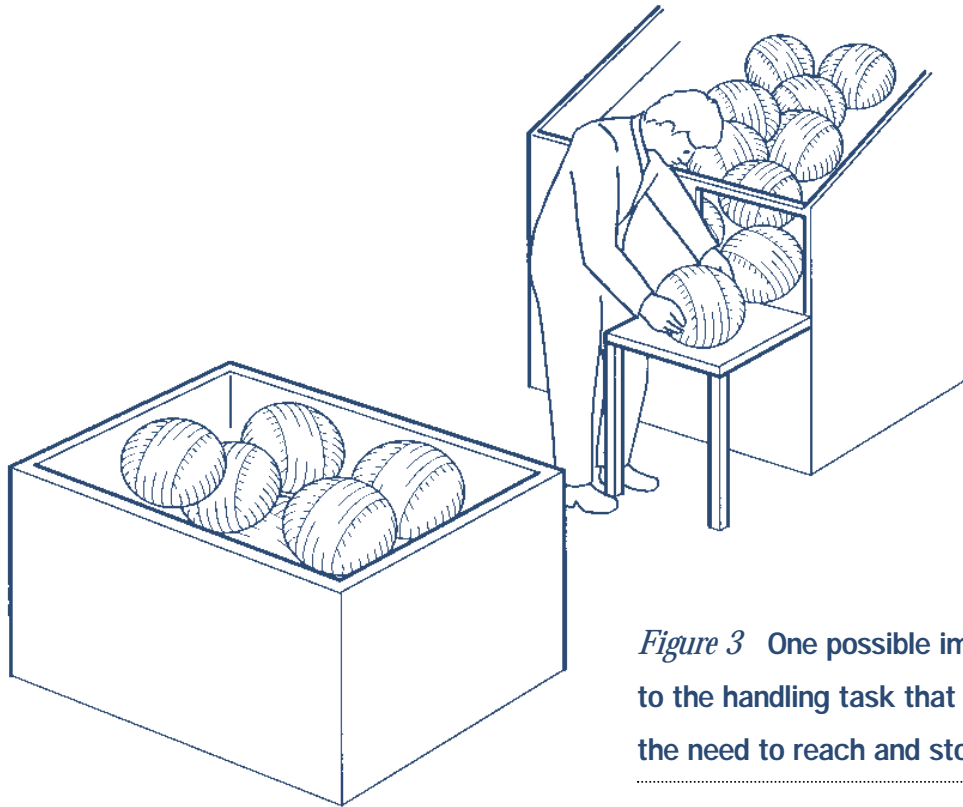

*Figure 3* One possible improvement to the handling task that reduces the need to reach and stoop

bin to grasp the bundle. The build-up of bundles also adds to the physical effort needed to pull and lift them clear of the bin.

**Solutions:** When designing the workplace, try to improve access to the bundles (eg with removable sections on the sides of the collection bins) and ensure they can be lifted from waist height and close to the body (see Figure 3). If possible, install a direct conveyor belt from the collector bin to the packing container.

**Other factors:** For repetitive handling tasks, consider carefully the way work is organised. For example, moving workers between a number of different jobs (job rotation), increasing the range of tasks within a job to

lengthen the handling cycle (job enlargement), and providing recovery time (where handling is not required) can all reduce the risks.

### **Handling rolls**

**Location:** Often performed close to machinery (lifting to and from weaving machines), in storage and despatch areas (lifting to and from shelves, racks, trolleys and stillages), and in quality control areas (weighing).

**Problems:** The weight and size of roll; the awkward postures adopted due to lack of space (reaching, stooping and twisting) especially if lifting from a low level; and grasping difficulties (it is often necessary to change the grip



*Figure 4* Awkward handling of rolls in a store

---

during the lift). There may be problems when lifting and handling in teams of two or more people, such as the uneven distribution of weight between individuals, differences in strength and stature, and co-ordinating the lift.

Figure 4 shows a roll of cloth being picked from a storage rack. It shows, for example, the difficulty of balancing and supporting the weight of the roll at shoulder height, as well as restricted and insecure footing.

***Solutions:*** In storage areas, consider mechanical methods of handling the rolls. Failing that, organise rolls according to weight so that heavier rolls are stored at a convenient height for handling. Handling aids like the adjustable width stacker in Figure 5 may be a practical solution. It has been specially designed for lifting and lowering rolls in storage areas. Roller track attached to the top of two support arms allows rolls to be passed



*Figure 5* An adjustable width stacker

---

easily to and from storage racks. The height of the trolley is easily adjusted using a foot pump. Resting on wheels, it can be readily manoeuvred. However, a worker may still need to use a ladder of some sort when pushing and pulling the rolls on or off the lifter.

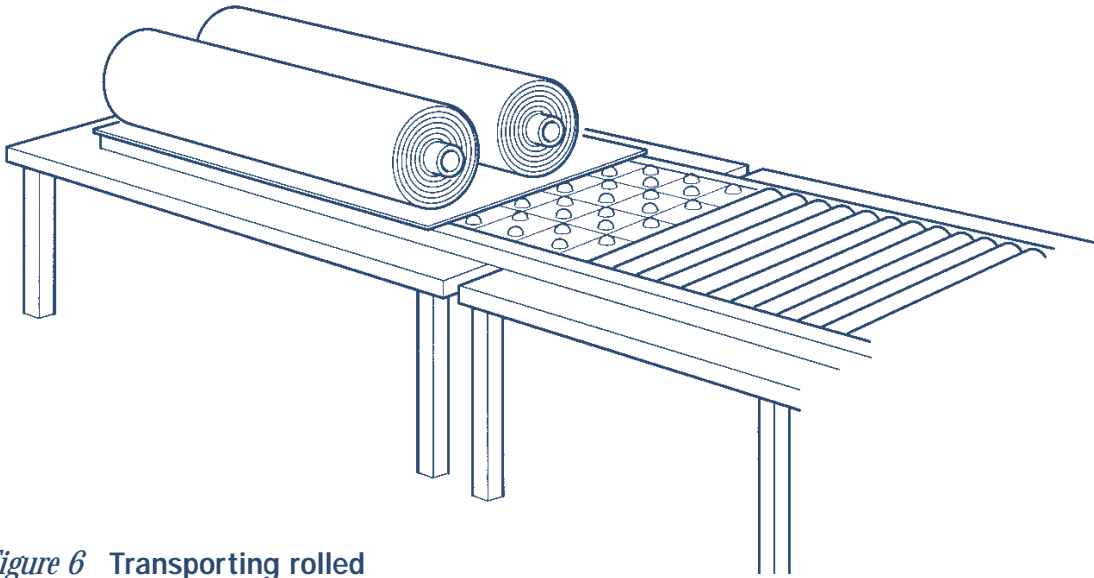

*Figure 6* Transporting rolled material on a roller conveyor

Figure 6 shows roller track used for moving rolls between different workstations in a packing department. Mounting roller track on table tops means the rolls can be maintained at a comfortable working height. The rolls rest on smooth, flat, lightweight boards, reducing the friction, as well as preventing the cloth from being damaged.

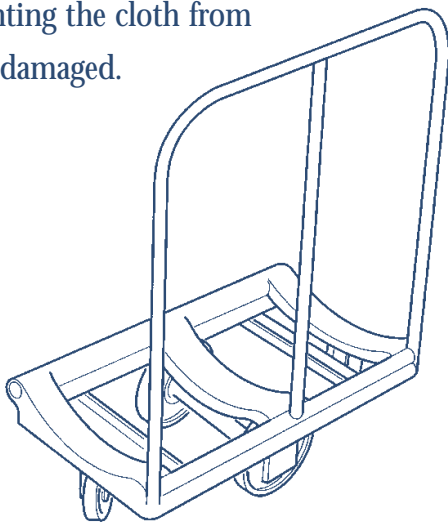
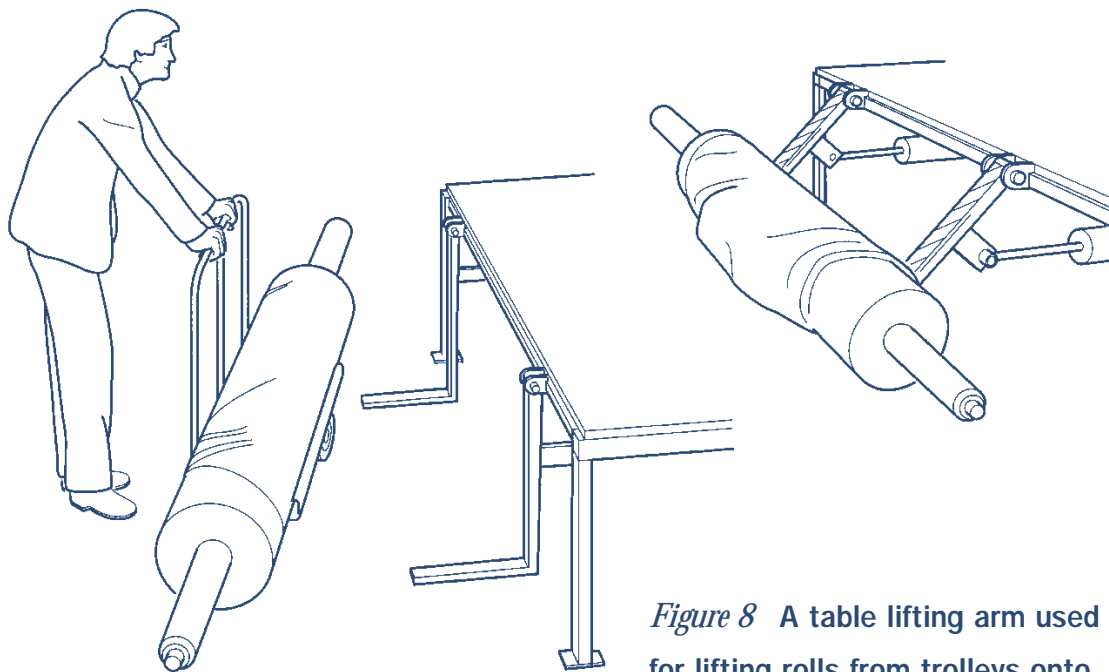

*Figure 7* A hand trolley for transporting rolls

Transferring rolls from the loom to other stages of the production process often results in several handling operations. Figure 7 shows a trolley specially designed for transporting and manoeuvring rolls about the confined spaces often found close to looms. The trolley is small and has two central load-bearing wheels with two smaller wheels at either end which allow it to be easily manoeuvred. A raised handle down one side of the trolley ensures the worker does not have to stoop.

To raise rolls onto a work surface, consider using a simple lifting arm, as shown in Figure 8, which is attached to the edge of the table. In this case, the lever arm is powered pneumatically.

Consider using an automated conveyor system to transport rolls to despatch. The conveyor delivers the roll

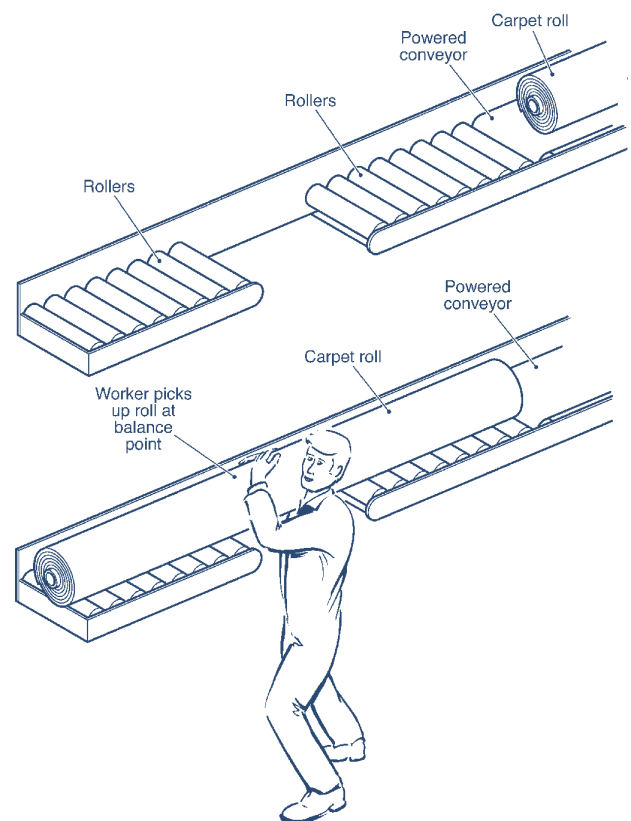

*Figure 8* A table lifting arm used for lifting rolls from trolleys onto the table

to an automatic weigh station. Rolls over a certain weight can be sent to a boom truck pick-up point for loading, while lighter rolls are diverted to a manual pick-up point (see Figure 9). The gap in the conveyor allows the workers to pick the roll up at its balance point, before carrying it to the vehicle. The conveyor can be used by left- and right-handed people.

See Figure 10 for an example of how to virtually eliminate manual handling. Rolls of cloth are handled by lift truck and loose cloth is transported in large trolleys towed by a small electric vehicle.

**Other factors:** Designing the layout of the work area is most important. The need to use maximum space in storage areas often means that access to items is difficult. Planning and good house-keeping will help reduce the likelihood



*Figure 9* Conveyor pick-up point that presents rolls at shoulder height

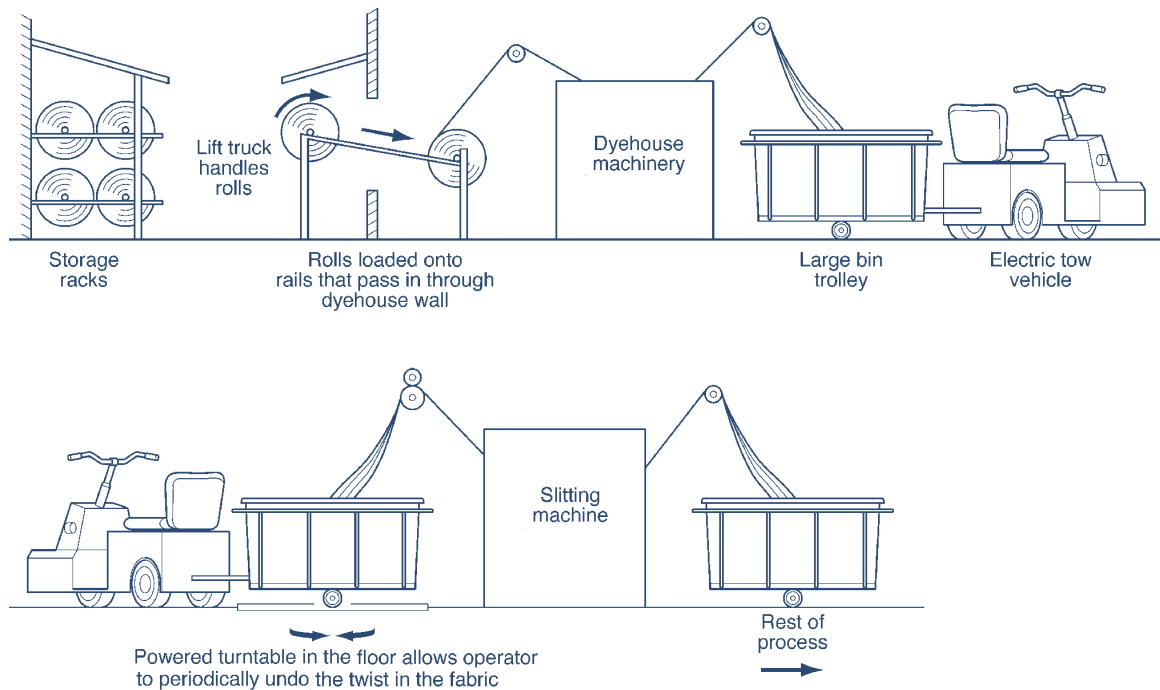
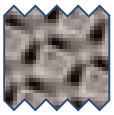

*Figure 10* How bulk handling has helped reduce manual handling in a dyehouse process

of accidents occurring. Consider installing a mechanical lifting aid, particularly in delivery and storage areas.

### **Handling loosely folded cloth**

**Location:** Common to a number of intermediate stages of the production process, for example, moving cloth to or from machines, inspection and quality control areas including lifting to or from weighing scales.

**Problems:** Risks arise from the weight of the cloth, its unstable nature (ie a

tendency to sag), the difficulties of ensuring a firm grasp on the load and the problems often associated with people lifting in teams. Figure 11 shows the tendency for folded cloth to sag when held at each end. This often results in more effort when lifting onto raised



*Figure 11* Lifting folded cloth

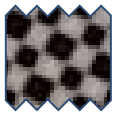

surfaces because the arms must be raised so much higher than the work surface. This is demonstrated by the woman on the right who must raise her arms well above the work surface, even though it is close to waist height.



*Figure 12* A lightweight stretcher-board used to carry folded material

**Solutions:** Figure 12 shows the use of a lightweight ‘stretcher-board’ which not only reduces the distance through which the load is lifted, but also improves its stability and provides for a more even distribution of weight between the two lifters. The board also has suitably designed hand-holds which improve grip and the ability to apply the necessary force during the lift.

The most effective way to prevent handling injuries is to avoid the need for handling altogether. Figure 13 shows



*Figure 13* Scales mounted into the floor so that material is weighed on the trolley

a weighing scale mounted into the floor close to the workstation. Rather than transferring cloth onto weighing scales and then putting it onto storage trolleys, the loaded trolley can be wheeled onto the scale for the cloth to be weighed, removing the need to lift the cloth.

### **Box handling**

**Location:** Mainly in delivery and storage areas, including to and from vehicles.

**Problems:** The size, shape and weight of boxes; awkward and constrained postures when lifting to and from storage racks; and the difficulties in grasping the load securely. Figure 14(a) shows boxes of yarn weighing up to 30 kg being stacked manually.

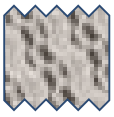
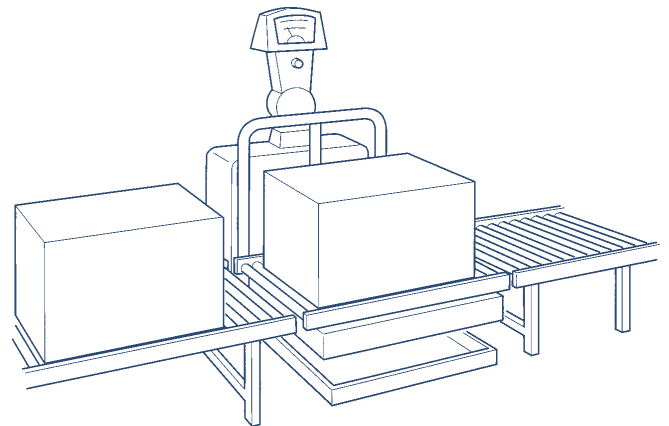

*Figure 14(a)* The original method of stacking boxes



*Figure 14(b)* New pneumatic handling equipment

**Solutions:** Figure 14(b) shows how the lifting operation has been mechanised by installing a vacuum handling system. Suspended on an overhead rail, the device is free to move within the storage area. Pneumatic grippers grasp the box securely and



*Figure 15* Scales built into a roller conveyor

compensate for the weight of the load, allowing it to be moved with minimal effort. The device can be adapted to suit a range of different items and containers.

Before despatching goods it is often necessary to weigh boxes, which can result in them being carried to and from the weighing scales. Consider mounting weighing scales in the floor or, alternatively, increasing the height of the surrounding work area to bring it in line with the height of the weighing scales. Figure 15 shows boxes being passed across the weighing scales along roller track, removing any need to carry, lift or lower them.

Conveyor belts offer flexible and effective means by which to transport packaged material over long distances. These can be powered or non-powered and are available with flexible telescopic



*Figure 16* An extendable, height adjustable, powered conveyor used to help in unloading

arms which can be adjusted to suit a range of different applications. Figure 16 shows a powered extendable conveyor belt used to unload boxes of yarn from the back of a lorry. The angle of the extended arm can be easily adjusted to suit the height at which the boxes are passed to the conveyor belt.

**Other factors:** Speak to suppliers to try and identify a packaging design that best suits the manual handling devices available. While reducing the weight of containers has significant benefits for most manual handling, in some instances, large, heavy containers may be more beneficial, discouraging manual handling and encouraging the use of mechanised procedures.

### *Lifting to and from bins, stillages, trolleys and machinery*

**Location:** Found in most areas but particularly common close to machinery.

**Problems:** Awkward trunk postures when lifting from the bottom of bins,



*Figure 17* A trolley with a self-levelling base



trolleys and stillages with rigid sides (eg bucket trolleys).

**Solutions:** To maintain a good trunk posture, the trolley shown in Figure 17 is fitted with a self-levelling base. The base is suspended from each corner of the trolley by four springs and, as material is removed, the suspended base rises, maintaining a constant height from which to lift. The opposite occurs when material is added. An inner lining



*Figure 18* Handling of cones to and from boxes

prevents material from being caught in the springs. The spring tension can be varied depending on the weight of the material being carried.

If self-levelling bucket trolleys are unsuitable, then consider whether improved access to the base of the trolley can be achieved by providing

drop-down sides or tilting the trolley towards the worker.

**Problem:** Figure 18 shows cones of spun yarn being removed from a conveyor and replaced by empty bobbins. This requires the worker to adopt an awkward posture to bend and reach sideways into the bottom of the stillage.

**Solutions:** Figure 19 shows how tilting platforms enable both trolleys to be angled towards the worker allowing easier access to the contents. Raising the height of the conveyor track and providing suitable seating also improve the posture the person adopts throughout the handling operation.

**Problem:** Moving drums of dye can result in some awkward handling.

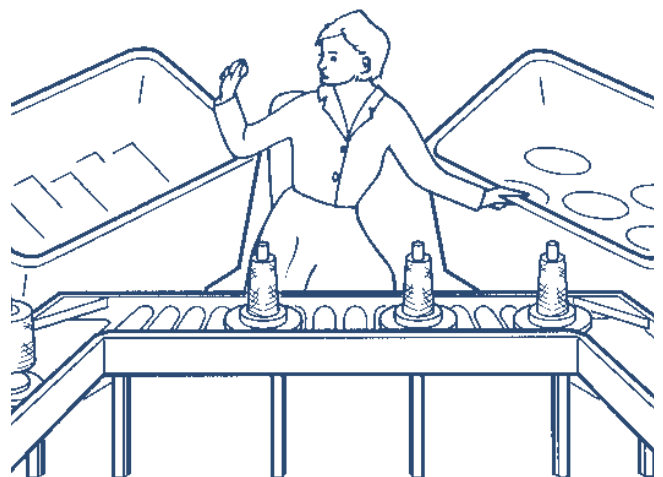

*Figure 19* Tilting trolleys can reduce reaching and improve working postures

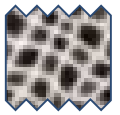

**Solution:** Consider using a simple purpose-made trolley (see Figure 20). The trolley is built so that its base is at the same level as the raised storage shelf making the transfer of the drums easier. This kind of trolley can only help where the floor is suitable, and it will need some maintenance of the wheels to ensure that it keeps running smoothly.

**Problem:** Awkward and forceful postures often stem from the way people

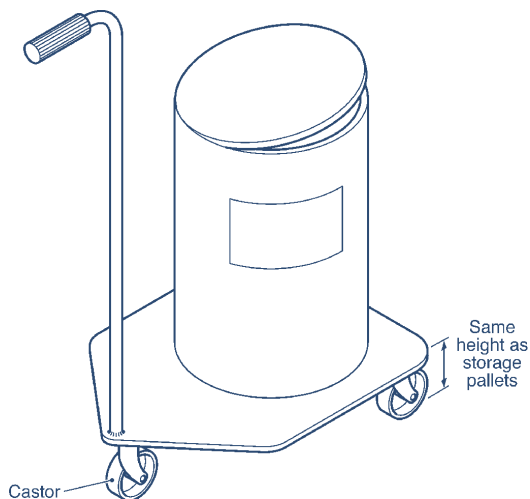

Figure 20 A drum trolley

interact with machinery. In Figure 21(a) the person adopts an awkward hand and arm posture while pushing down on the bobbin (a similar posture is adopted to remove full bobbins).

**Solution:** Modifying machinery is expensive, but simple tools to assist handling operations may provide a

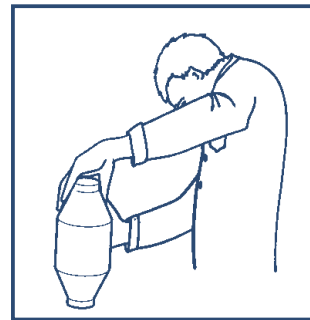

Figure 21(a)

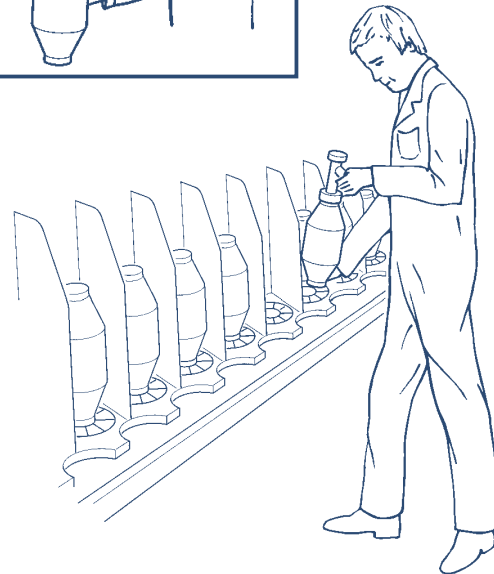

Figure 21(b) A handling aid for lifting bobbins

cost-effective alternative. Figure 21(b) shows how a hand tool, which is designed to lock onto the head of the bobbin, allows the hand and arm to adopt much more suitable positions.

**Problem:** The handling of heavy yarn packages is a common activity.

**Solution:** Figure 22 shows how reducing the risks associated with this often repetitive task may be best achieved using a mechanical handling device. This is suspended from an overhead support or rail, grips the



*Figure 22* A mechanical lifting aid for packages of yarn

centre of the package, and by balancing and supporting the load it helps with lifting and manoeuvring the packages.

**Other factors:** It is important to consider the size of individual users in relation to the machinery they operate. If one person has responsibility for one or several pieces of machinery, then ensure that the handling aids provided are suitable for the individual. Where several operators use the same machinery, then consider handling aids which can be easily adjusted.

## Maintenance

**Location:** Most areas.

**Problems:** Maintenance tasks can lead to some of the most hazardous handling operations. They are often performed in confined and restricted space in and around machines. While many are routine and frequently undertaken, some are more varied and unpredictable requiring more effort to plan and control the activity. Some tasks require workers to support heavy components while bolts are removed or replaced. The main risk factors are the weight of the component parts (often in excess of 50 kg), restricted access and consequent awkward postures, and insecure footing.

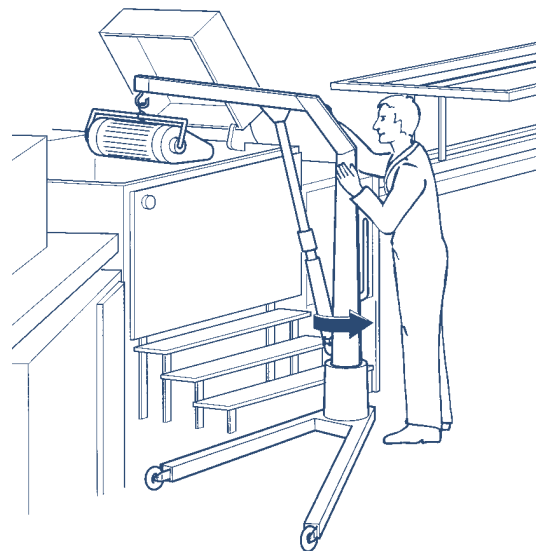

*Figure 23* A hoist used for lifting and manoeuvring heavy parts during maintenance



*Figure 24* A tool-box trolley

**Solutions:** Planning during machine installation can help, eg by allowing access, providing overhead hoists and lifting points such as eyebolts. However, flexible multi-purpose handling devices can be more practical than alterations to the workplace. Mobile hoists, similar to the one in Figure 23, and even motor vehicle jacks can provide mechanical assistance. Aim to minimise handling

requiring changes in height and the supporting of heavy loads.

Handling tool boxes is often taken for granted and yet this too can involve repetitive lifting of heavy loads, usually with one hand. Figure 24 shows a simple tool-box trolley.

**Other factors:** Good maintenance also includes the regular upkeep of machinery, and good housekeeping practices. This is one of the first line approaches towards accident prevention. For example, trolleys are used extensively throughout the industry and play a major part in reducing manual handling. However, poorly maintained wheels can become clogged with waste material or stick due to wear, increasing the force that must be exerted to move them. Systematic cleaning and maintenance of wheels, perhaps including a simple record, will help ensure that risks of injury are minimised. Well-maintained floors will also benefit the users of trolleys.

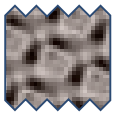

## References and further reading

**1** *Manual handling. Manual Handling Operations Regulations 1992. Guidance on Regulations* L23 HSE Books 1992  
ISBN 0 7176 0411 X

**2** *Management of health and safety at work. Management of Health and Safety at Work Regulations 1992. Approved Code of Practice* L21 HSE Books 1992  
ISBN 0 7176 0412 8

**3** *Getting to grips with manual handling: A short guide for employers*  
INDG143 HSE Books 1993

The future availability and accuracy of the references listed in this publication cannot be guaranteed.

## Further information

HSE priced and free publications are available by mail order from:

**HSE Books**

**PO Box 1999**

**Sudbury, Suffolk CO10 6FS**

**Tel: 01787 881165**

**Fax: 01787 313995**

HSE priced publications are also available from good booksellers.

For other enquiries ring

**HSE's InfoLine Tel: 0541 545500,**

or write to **HSE's Information Centre,  
Broad Lane, Sheffield S3 7HQ.**

HSE home page on the World Wide Web:

**<http://www.open.gov.uk/hse/hsehome.htm>**

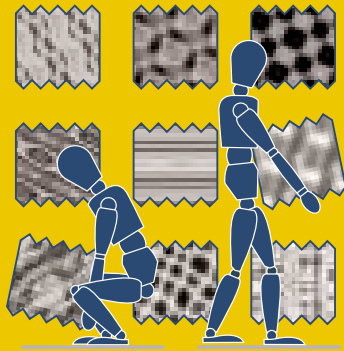

This leaflet was prepared by the Textiles Industry Advisory Committee and has been agreed by the Health and Safety Commission. It contains notes on good practice which are not compulsory but which you may find helpful in considering what you need to do.

This leaflet is available in priced packs of 10 from HSE Books, ISBN 0 7176 1516 2. Single free copies are also available from HSE Books.

This publication may be freely reproduced, except for advertising, endorsement or commercial purposes. The information is current at 3/98. Please acknowledge the source as HSE.